	<b>ENMAX CORPORATION</b>		
	<b>GROUND DISTURBANCE GUIDELINES</b>		
	Verify revision is current prior to use.	Effective Date: December 19, 2024	Page 1 of 19



Scan the above QR Code to obtain the most current version.

	<b>NOTE: FOR ALL EMERGENCIES IMMEDIATELY STOP AND CONTACT 9-1-1</b>
---	---

Approved By:	Title	Date Approved
Chris Smith	Director, Safety and Environment	December 18, 2023
Dean Battershill	Manager, Operational Safety	December 18, 2023

# Table of Contents

1.0	INTRODUCTION.....	3
1.1	PURPOSE.....	3
1.2	KEY CONTACTS.....	3
1.3	REFERENCES.....	3
1.4	GLOSSARY.....	3
2.0	GROUND DISTURBANCE PROCESS.....	5
2.1	LOCATES.....	6
2.2	NON-DESTRUCTIVE ZONE.....	6
2.3	ENMAX PERMISSION LETTER.....	7
2.4	NOTIFICATIONS FOR EXCAVATION ACTIVITIES.....	7
2.5	COMPLETE GROUND DISTURBANCE.....	7
2.6	BACKFILL.....	8
2.7	PROCEDURE – IF DAMAGE OCCURS.....	8
	APPENDIX A – SAFE WORK PRACTICES.....	9
	APPENDIX B – CONFLICT ZONE.....	10
	APPENDIX C – EXCAVATION METHODS.....	11
	APPENDIX D – ENGINEERED SUPPORT REQUIREMENTS.....	14
	APPENDIX E - REVISION HISTORY.....	18

# 1.0 INTRODUCTION

## 1.1 PURPOSE

Ground disturbance, or excavations, poses significant hazards to workers, the public, and the environment. This document provides requirements companies and individuals MUST comply with when exposing buried ENMAX facilities. Other sources to comply with include provincial legislation, codes, bylaws, and other utility requirements.



**WARNING:** Use extreme caution when working near energized cables; consider ALL power cables energized. Contact with cables may cause injury or death; therefore, excavators **MUST** contact their project inspector or access the [Temporary Disconnect/Reconnect Form](#) to schedule switching and isolation of energized cables if cable support is needed. Proximity Agreements will be required in Downtown/Network Areas.



**NOTE:** If energized cables cannot be isolated and grounded, companies must adhere to their own hand exposure and hydrovac safe work practices.

## 1.2 KEY CONTACTS

The following must be readily available when conducting ground disturbance near ENMAX facilities.

### Key Contacts

Contact	Phone Number	Email
Utility Safety Partners	1-800-242-3447	<a href="http://www.utilitysafety.ca">www.utilitysafety.ca</a>
ENMAX Customer Projects		<a href="mailto:getconnected@enmax.com">getconnected@enmax.com</a>
ENMAX Field Services (MSO, and anchor and guy removal)		<a href="mailto:EPCFieldServicesMSOs@enmax.com">EPCFieldServicesMSOs@enmax.com</a>
ENMAX Hot Digs		<a href="mailto:HotDigs@enmax.com">HotDigs@enmax.com</a>
ENMAX Line Inspection		<a href="mailto:lineinspection@enmax.com">lineinspection@enmax.com</a>
ENMAX Transmission	403-514-3679	
ENMAX Trouble Dispatch	403-514-6100	
ENMAX Proximity Agreements		<a href="mailto:HotDigs@enmax.com">HotDigs@enmax.com</a>

## 1.3 REFERENCES

All work must be carried out in accordance with the following:

### Legislation

[Alberta Occupational Health and Safety Code](#)

- Part 17 Overhead Power Lines
- Part 18 Personal Protective Equipment
- Part 32 Excavating and Tunneling

[Alberta Electrical Utility Code](#)

- Section 2- 014 Activities near Overhead Power Lines
- Section 2- 018 Moving Equipment or Buildings
- Section 2- 020 Excavation Activities in the Vicinity of Underground Power Lines

CAN/CSA Standard C22.3 No. 7-10 Underground Systems

CAN/ULC-S801-(7.15.6) Standard on Electric Utility Workplace Electrical Safety

### ENMAX form

[Temporary Disconnect/Reconnect Form](#)

### ENMAX Resources

ENMAX Hazardous Electrical Awareness Tutorial

NOTE: Available upon request at [hotdigs@enmax.com](mailto:hotdigs@enmax.com)

### Other resources

- [Canadian Common Ground Alliance](#)
- [Utility Safety Partners](#)

## 1.4 GLOSSARY

### Acronyms

AEUC

| Alberta Electrical Utility Code

| MSO

| Minor Service Order

CSA	Canadian Standards Association	PPE	Personal protective equipment
HRC	Hazard Risk Category	QUE	Qualified Utility Employee
LOA	Limits of Approach (Safety Code)	SWP	Safe Work Practice

### Terms

Air excavation / hydrovac equipment	A non-destructive process using pressurized water or air and a vacuum truck to remove earth cover (soil, gravel, stones, rubble, mud).
Competent worker	A worker who is adequately qualified, suitably trained, and with sufficient experience to safely perform work without supervision or with only a minimal degree of supervision.
Conflict zone	At risk locations within the work area for any of the following: <ul style="list-style-type: none"> <li>• Listed on the locate slip by the Locator</li> <li>• Within <b>1 m (3'-3")</b> of any locate marks</li> <li>• Within <b>2 m (6'-6")</b> of any ENMAX at-grade facility</li> <li>• Within <b>3 m</b> of any Manhole or Vault</li> <li>• Within <b>5 m</b> of any ENMAX Underground Transmission 69-kV or 138-kV cables</li> <li>• Within <b>5 m</b> of the underside of a Manhole or Vault</li> <li>• As described in <a href="#">Appendix B - Conflict Zone</a></li> </ul>
Destructive excavation	An operation using equipment or explosives to move earth, rock, or other material below existing grade.
ENMAX facilities	ENMAX facilities include: <ul style="list-style-type: none"> <li>• Cables and ducts</li> <li>• Concrete duct banks</li> <li>• Guy wire w/pole anchors</li> <li>• Manholes</li> <li>• Poles</li> <li>• Pull boxes</li> <li>• Switches</li> <li>• Transformers</li> <li>• Transformer vault</li> <li>• Transmission infrastructure</li> <li>• Secondary pedestals and tubs</li> </ul>
Excavator	Any contractor, developer, property owner, or other individual performing any work, operation or activity that results in a disturbance of the ground, regardless of depth.
Ground disturbance	Any work, operation, or activity that results in a disturbance of the ground, regardless of depth.
Hot dig	Process of exposing energized cables and facilities using non-destructive methods.
Locate marks	Temporary markings to identify the approximate location of underground infrastructure (buried facility). Examples include pin flags, coloured paint, stake chasers, coloured chalk, chevron.
Non-destructive zone	One (1) metre (3'-3") from either side of the locate marks or flags
Non-destructive excavation	Hand exposure (provided there is a non-conductive handle on shovel), air vacuum or hydrovac equipment.

## 2.0 GROUND DISTURBANCE PROCESS

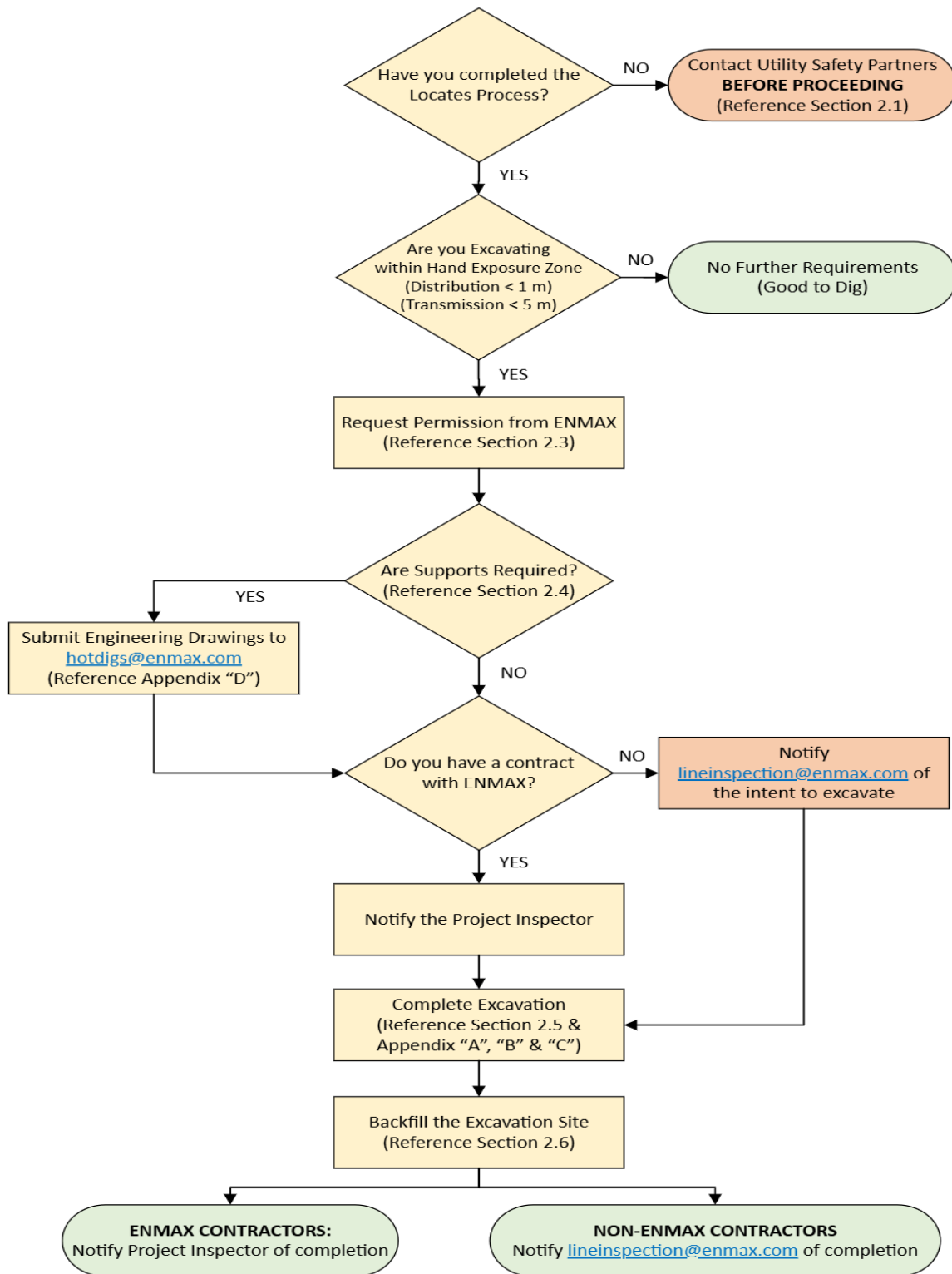

## 2.1 LOCATES

### ENMAX underground facilities

Submit an online locate request at [Utility Safety Partners](#) PRIOR to any ground disturbance near ENMAX facilities.

Call Utility Safety Partners directly at **1-800-242-3447** for the following:

- Request emergency locates
- Provide damage information



**NOTE:** Inside property-private owners; includes commercial lots, multi-dwelling, provincial highways/roadways, and utility corridors (streetlighting and fibre) must obtain locates for secondary conductors via private utility locating service provider of choice.

### At grade facilities

System ground wires and ground rods are not locatable. They are typically buried below the final grade and encompass a **1 m (3'-3")** area around or adjacent to ENMAX facilities.



**CAUTION:** Contacting the ground system may cause damage to the adjacent structures or equipment and/or personal injury or death. Only Non-destructive excavation in accordance with this Guideline may be performed when disturbing the ground within **2 m (6'-6")** of equipment.

## 2.2 NON-DESTRUCTIVE ZONE

### Within the non- destructive zone



**MECHANICAL EXCAVATION IS NOT PERMITTED WITHIN NON-DESTRUCTIVE ZONES** (refer to [Appendix B](#))

Locate marks (chevron), shown below, depict the location of underground facilities.

The conflict zone (non-destructive) extends **1 m (3'-3")** beyond the locate marks.

Contact information for **OTHER facility owners** can be found on the **back of the locate slip** provided by the locate service provider.

### LOCATOR'S PAINT MARKS

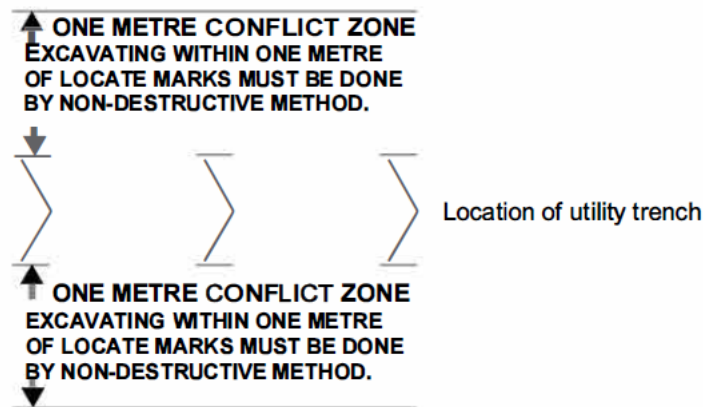

**NOTE:** Locate marks are valid for **60 days** from the date provided unless otherwise specified.

### Outside the Non- Destructive zone

If the ground disturbance occurs **OUTSIDE** the non-destructive zone, ENMAX has no restrictions on the ground disturbance. Excavation may proceed (subject to requirements of provincial legislation, codes, bylaws, and other utilities).

## 2.3 ENMAX PERMISSION LETTER

**Permission Letter** Obtain an ENMAX Permission Letter PRIOR to performing ground disturbance near ENMAX facilities. The Letter MUST remain on site while exposing ENMAX facilities. Email [HotDigs@enmax.com](mailto:HotDigs@enmax.com) to obtain an ENMAX Permission Letter.

**Excavator requirements** Excavators MUST comply with the following requirements:

- Create and adhere to own SWPs for ground disturbance (reference [Appendix A – Safe Work Practices](#) for minimum requirements)
- Ensure all personnel involved in any ground disturbance are competent workers
- Supervisor of the Excavation has Ground Disturbance Level II training
- Ensure SWP and procedures comply with this guideline, legislation, bylaws, codes
- Ensure a cell phone or other means of contacting ENMAX Trouble Dispatch is always available while at the worksite
- Comply with all requirements contained in the ENMAX Permission Letter

## 2.4 NOTIFICATIONS FOR EXCAVATION ACTIVITIES

**ENMAX Projects – Contract in Place** Contact the ENMAX Project Inspector when performing work for ENMAX and a contract exists between ENMAX and the contractor.

**Non-ENMAX projects** Notifications for non-ENMAX projects are outlined below.

If...	Then...
Damage to ENMAX Infrastructure	Call Trouble Dispatch at 403-514-6100 or Project Inspector Reference <a href="#">Section 2.7 Procedure - If Damage Occurs</a> .
Engineering supports are required for pull boxes, transformers, duct banks, poles, cables, and cables in duct of 1.2 m and longer	Submit stamped engineering drawings to <a href="mailto:hotdigs@enmax.com">hotdigs@enmax.com</a> a minimum of 14 days prior to planned excavation for facility support approval. Reference <a href="#">Appendix D</a>
Working within the Downtown Core or Beltline	Work Scope Plans and Diagrams need to be submitted to <a href="mailto:hotdigs@enmax.com">hotdigs@enmax.com</a> , 6 months prior to construction starting. Proximity/ Crossing Agreement will also be required.
Work is within <b>2 m (6'-6")</b> of ENMAX facilities	Complete the steps below a minimum of <b>5 days prior</b> to planned excavation. <ol style="list-style-type: none"> <li>Notify <a href="mailto:lineinspection@enmax.com">lineinspection@enmax.com</a> for intent to excavate.</li> <li>If deemed necessary, complete the ENMAX <a href="#">Temporary Disconnect/Reconnect Form</a> for ground grid protection around transformers, rigging and slinging of cables, or isolation and grounding where practicable.</li> <li>If required, request a Minor Service order to schedule ENMAX personnel to complete the request.</li> </ol>
Anchor and guy removal	Request a Minor Service Order (MSO) to schedule ENMAX personnel to complete the request. Email the following: <ul style="list-style-type: none"> <li>• <a href="mailto:lineinspection@enmax.com">lineinspection@enmax.com</a></li> <li>• <a href="mailto:EPCFieldServicesMSOs@enmax.com">EPCFieldServicesMSOs@enmax.com</a></li> </ul>
Backfill inspection	Follow the process in <a href="#">Section 2.6 Backfill</a> .

## 2.5 COMPLETE GROUND DISTURBANCE

**Perform ground disturbance** Complete ground disturbance in accordance with this Guideline; requirements include:

- Compliance with instructions & restrictions conveyed by the permission letter
- [Appendix A – Safe Work Practices](#)
- [Appendix B – Conflict Zone](#)
- [Appendix C – Excavation Methods](#)

## 2.6 BACKFILL

### Notification

Notify the following PRIOR to backfilling the site.

If work is for	Then contact the following PRIOR to backfilling...
ENMAX	Project Inspector to arrange for inspection
Other MON-FRI (06:00 and 16:00)	Damage Prevention Dept. at <a href="mailto:LineInspection@enmax.com">LineInspection@enmax.com</a>
After hours	Trouble Dispatch at <b>403-514-6100</b> to arrange inspection



The use of unshrinkable fill / fillcrete must be approved by ENMAX civil engineer. Backfill shall be in accordance with City of Calgary Road specification and ENMAX compaction guideline.

- Common fill shall be compacted to 98% SPMDD in uniform layers not exceeding 300 mm when compacting with hand tamping equipment and 600 mm when using hydraulic equipment.



**NOTE:** Restore final grade to ensure the burial depth of ENMAX cables has not changed. Contact your ENMAX Inspector if a rise or fall in the final grade exists **PRIOR** to excavation and backfill to record the new grade. For all others, call 403-514-6100

## 2.7 PROCEDURE – IF DAMAGE OCCURS

### Procedure

If damage occurs complete the following steps:

Step	Action
1.	<b>STOP WORK!</b>
2.	<b>Exit</b> the work site immediately.
3.	<b>Call 911</b> if an injury has occurred.
4.	<b>Secure</b> the site; use appropriate signs, barriers, or barricades.
5.	<b>Contact</b> ENMAX Trouble Dispatch at 403-514-6100, and the Project Inspector if required.
6.	<b>Call</b> 1-800-242-3447 to submit a damage ticket and complete online reporting via <a href="#">Utility Safety - Damage Reporting</a>



**WARNING:** Do **NOT** re-enter the excavation site until clearance has been given and repairs have been completed by an ENMAX QUE.



**NOTE:** *Repairs can only be completed by ENMAX. All costs will be incurred by the party causing repair requirement.*



## APPENDIX A – SAFE WORK PRACTICES

### Barriers and barricades

Excavators are responsible for the following:

- **Prevent** exposed energized equipment and cables from public contact
- **Restrict** access to all open excavations during periods of inactivity (unsupervised); may include a cover, barricade, **1.8 m (6') rigid fence**

### Personal protective equipment (PPE)

A minimum of the following PPE is required for all ground disturbance activities within the conflict zone; for hand exposing only.

Reference AB OH&S Part 18.

Protective clothing	Fire resistant outer layer clothing, ankle to cuff <b>NOTE:</b> HRC 2 (8 Cal/ cm2) minimum
Safety glasses	CSA Z94.3 Eye and Face Protectors with a minimum IR rating of 1.7
Rubber gloves	Tested - Class 3 high voltage rubber insulated gloves (rated at 30,000 volts) with outside leather protectors.
Head protection	CSA Approved Class E Hard Hat
Hearing protection	CSA approved hearing protection (if required)
Footwear	CSA approved dielectric footwear with the following symbols: 

### Warning signs

If the job site and equipment are left unsupervised, signs in accordance with the excavator's procedures **MUST** be visible. Minimum information to include:

- Caution or Warning of open excavation
- Name of ground disturber
- Emergency contact number

“**DANGER HIGH VOLTAGE**” sign must be located a minimum of **3 m (9'-10")** from the truck to reduce the risk of injury from step and/or touch potential.



**WARNING:** Do NOT touch any vehicles while excavating is in progress to avoid touch potential (electrocution may occur). A minimum of **2 m** distance should always be maintained.

## APPENDIX B – CONFLICT ZONE

### Shallow primary and secondary cables



All underground facilities must be fully exposed to sight using non-mechanical / destructive methods. Mechanical excavation is **NOT** permitted within **1 m (3'-3")** of all exposed underground facilities in all directions.



**WARNING:** Shallow electrical facilities may exist directly underneath the asphalt or concrete sidewalks; therefore, asphalt and concrete cutting and removal directly over a marked facility is **NOT PERMITTED** until the depth of the facility is exposed to sight. Confirm the depth and position under the asphalt **PRIOR** to saw cutting across the facility. See [2.1 Asphalt Removal](#).

### Underground transmission equipment and cables

If an ENMAX disclaimer for “No Clearance” exists on the locate slip, then mechanical excavation work is **NOT** permitted within **5 m (16'-5")** on either side of the locate mark. Contact **ENMAX Transmission Inspector at 403-514-3679**. Reference ENMAX note located on the back of the Utility Safety Partners ticket for direction.

### Above Grade facilities

Mechanical excavation is **NOT** permitted within **2 m (6'-6")** of any ENMAX facilities; use non-destructive methods **ONLY**. Reference ENMAX note located on the back of the Utility Safety Partners slip for direction and notification. Refer to [2.4](#).

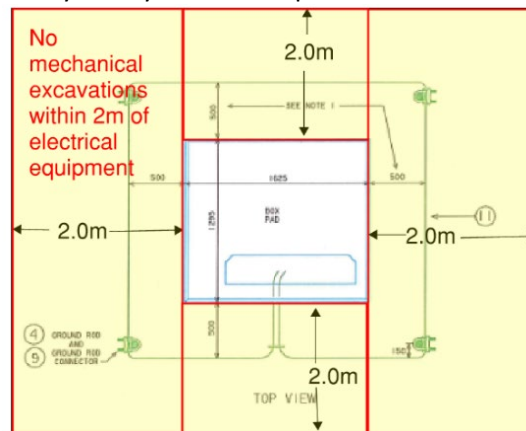

### Overhead electrical lines

Ground disturbance may occur near overhead electrical lines. The excavator must ensure safe distances to electrical lines and equipment are adhered to; reference [AEUC Table 1 - Safe Limits of Approach Distances from Overhead Power Lines for Persons and Equipment](#) for additional information. This table is also referenced in the following:

- AB OH&S Code - Schedule 4
- AB OH&S Code - Part 17 Overhead Power Lines



**NOTE:** Personnel and equipment must stay a minimum of **7 m (~23')** from all overhead lines.

Contact one of the following if work is required closer than **7 m (~23')** for LOA:

If...	Then contact the following to arrange an inspection
ENMAX Project	Project Inspector
Mon thru Fri 6 AM to 4 PM	Damage Prevention - <a href="mailto:LineInspection@enmax.com">LineInspection@enmax.com</a>
After hours/weekends	Trouble Dispatch at <b>403-514-6100</b>

## APPENDIX C – EXCAVATION METHODS

---

### 1. AIR EXCAVATION METHOD

#### Minimum equipment specifications

Air excavation uses pressurized air that is used to slough away soil and is subsequently collected by a vacuum tool such as an Air Spade.

At a minimum, when using air excavation ensure that:

- Air pressure does **NOT exceed 100 psi**
- Vacuum dig tube end has a neoprene lip or equivalent
- Non-conductive wand, tube, and hose extensions



**CAUTION:** Any air pressure above the listed values is considered a destructive means of excavating.

#### Potential risks to facilities

Cable damage may occur if falling rocks or sloughing material contact exposed cables or ducts. If damage is suspected, reference [Section 2.7 Procedure - If Damage Occurs](#).

#### Minimum safety precautions

Ensure the following minimum safety precautions when exposing cables using air excavation:

- Do **NOT** allow the wand to become stationary
- Make a sweeping motion during use perpendicular to the cables (vs. lengthways); this eliminates stationary contact with the cable at the end of each sweep
- After the buried facility is exposed, maintain a minimum distance of **175 mm (7")** between the cable and the wand nozzle
- Avoid positioning the vacuum tube directly over exposed facilities



**WARNING:** The air wand and vacuum pipe may become energized if faulted conditions exist.

### 2. HAND EXPOSURE METHOD

#### Minimum equipment specifications

Ensure the following **minimum** requirements when using shovels to hand expose underground cables:

- Shovels have dry, non-conductive handle
- Pointed probes that may pierce the cables are not used

#### Potential risks to facilities

Cable damage may occur if the shovel hits the cable. If damage is suspected, reference [Section 2.7 Procedure - If Damage Occurs](#).

#### Minimum safety precautions

Ensure the following minimum safety precautions when exposing cables with a shovel:

- Use PPE as per [APPENDIX A](#)
- Expose cables to sight at regular intervals (minimum of 5 m)
- No mechanical means within 600 mm (24") once line is exposed
- Use extreme caution when working within **1.5 m (≈5')** of any cable splices.
- During business hours notify [lineinspection@enmax.com](mailto:lineinspection@enmax.com) or Project Inspector to arrange for inspection prior to backfilling.
- After hours contact ENMAX Trouble Dispatch at **403-514-6100**.



**WARNING:** Do not move, walk on, or disturb cable splices while hand exposing cables.

### 3. HYDROVAC METHOD

#### Minimum equipment specifications

At a minimum, when using hydrovac, ensure:

- Water pressure does **not exceed 1500 psi**
- Water temperature does **not exceed 37.8 °C (100 °F)**
- Vacuum pipe end has a neoprene lip or equivalent to protect the cable/facilities
- There is a single oscillating tip nozzle
- The wand is always moving



**CAUTION:** Any pressure or temperature variances above the listed values is considered a destructive means of excavating.

#### Potential risks to facilities

A combination of the water temperature and pressure may damage cables. Damage may appear as a slice in the cable sheath of an unknown depth, or as though the outer sheath has been torn and pulled outward. If damage is suspected, reference [Section 2.7 Procedure - If Damage Occurs](#).

#### Minimum safety precautions

Ensure the following minimum safety precautions when exposing cables with hydrovac:

- Expose cables to sight with Test Holes
- at a minimum of **5 m (~16')** intervals to verify line orientation and depth consistency
- Direct the high-pressure nozzles in a circular motion
- Do NOT allow the wand to become stationary
- Make a sweeping motion during use perpendicular to the cables (vs. lengthways); this eliminates stationary contact with the cable at the end of each sweep
- After the buried facility has been exposed, maintain a distance of at least **175 mm (7")** between the cable and the oscillating head of the water wand
- Avoid positioning the vacuum tube directly over exposed facilities
- Avoid leaving excess water in the trench



**WARNING:** The water, wand, and vacuum pipe may become energized if faulted conditions exist.

#### 4. DESTRUCTIVE EXCAVATION AND DIRECTIONAL CORING

##### Equipment

Includes the following equipment after a facility has been exposed to sight:

- Auger
- Directional drills
- Ditch witch
- Dozer, grader
- Hammer (electric, hydraulic)
- Plows
- Pneumatic jack hammers
- Post pounders
- Saw (asphalt, concrete)
- Scrapers
- Skid steers
- Track or rubber tire hoe

##### Potential risks to facilities

Destructive excavation methods have the potential to damage underground equipment and buried facilities. If damage is suspected, reference [Section 2.7 Procedure](#).



**WARNING:** If any part of the equipment contacts an energized cable, the equipment operator **MUST** remain on the machine (if safe to do so) until given a clearance from an ENMAX QUE.

##### Minimum safety precautions

Ensure the following minimum safety precautions when directional coring or using other destructive excavation methods:

- Observe the payload when pulling back through the excavation
- Maintain **1 meter** of separation / clearance above, below, and parallel to the cable / facility
- Expose cables to sight with Test Holes at sufficient intervals to maintain separation (typically every 5 m but it may vary based on site specific conditions)
- Spotters **MUST** always be present when using excavation equipment
- Calibrate all tools and ensure strike indicator is operational
- At no point, exposed or not, can you use mechanical tools on ducts with energized cable...No chipping of ducts/duct banks.

##### Shallow Cables in Downtown Network



**CAUTION:** When crossing all facilities expose the facilities to sight **AND** a minimum of **1 m (3'-3")** exposed on the drill side **PRIOR** to coring or drilling. This allows the operator time to stop the task if the drill head approaches the cable/duct.

## APPENDIX D – ENGINEERED SUPPORT REQUIREMENTS

### Cable/duct bank support

SUPPORT SYSTEM REQUIREMENTS FOR ENMAX CABLES is available here. See NOTES below:

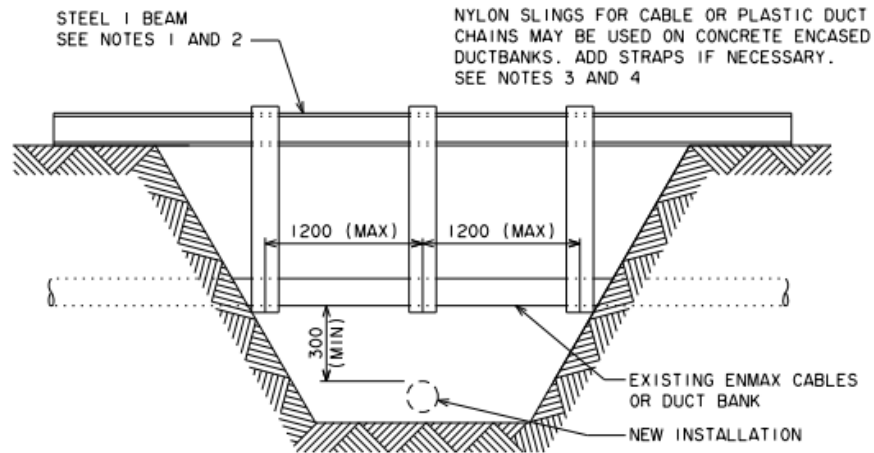

FIGURE 1  
CABLE & DUCTBANK SUPPORT

### NOTES:

1. The actual size of support beams and slings shall be the responsibility of the contractor. The support system shall be designed to prevent sag, bending or deflection in cables or duct banks.
2. The contractor shall be responsible for ensuring no damage to cables, ducts or duct banks takes place while employing the support system. Any damage shall be reported to the ENMAX inspector immediately. Work shall not commence until submitted drawings have been approved by ENMAX Civil Engineer.
3. The beam shall be in the form of a steel "I" beam set across the excavation running parallel with ENMAX cables or ducts. The beam must adequately support the cable or duct bank.
4. The contractor shall be responsible for supplying all material. Labour and equipment required to implement an adequate support system.
5. The engineer who stamped and approved the drawing is obligated to inspect and verify all work completed by the contractor is compliant.



**Underground facilities**

Excavators supply the following to support cables, duct banks, transformers, switches, manholes, vaults and pull boxes in underground facilities subject to ENMAX's approval.

Supports	Requirements
Beams	<ul style="list-style-type: none"><li>• Steel "I" beam (excavator to determine the size)</li></ul> <p><b>NOTE:</b> Submit stamped engineering drawings to <a href="mailto:Hotdigs@enmax.com">Hotdigs@enmax.com</a></p> <ul style="list-style-type: none"><li>• Place across the excavation parallel with the undermined facility</li><li>• Design to prevent sag, bending, and deflection</li><li>• Sufficient length to reach a minimum of 3 m (9'-10") beyond the edge of the excavation (on both sides)</li><li>• Supporting structure will not slough into the excavation due to unstable soil conditions</li></ul>
Chains	<ul style="list-style-type: none"><li>• Support concrete encased duct banks</li></ul>
Slings	<ul style="list-style-type: none"><li>• Direct buried cable or ducts must be supported by nylon slings</li><li>• Must be properly rated to hold the structure</li></ul>
Transformers, switches, manholes, vaults and pull boxes	<ul style="list-style-type: none"><li>• Must NOT be undermined and must be supported</li><li>• Contact <a href="mailto:lineinspection@enmax.com">lineinspection@enmax.com</a> to determine next steps.</li><li>• Engineered support system may be required as a submission to brace / support</li></ul>



## Power poles

ENMAX requires excavators to stabilize poles and associated equipment, where required below, prior to any ground disturbance.



**WARNING:** The collapse of a power pole could expose individuals to a crush hazard or electrocution.

Poles must be supported if:

- The soil is not firm
- Excavation occurs within the **shaded protected zone** shown in the illustration below

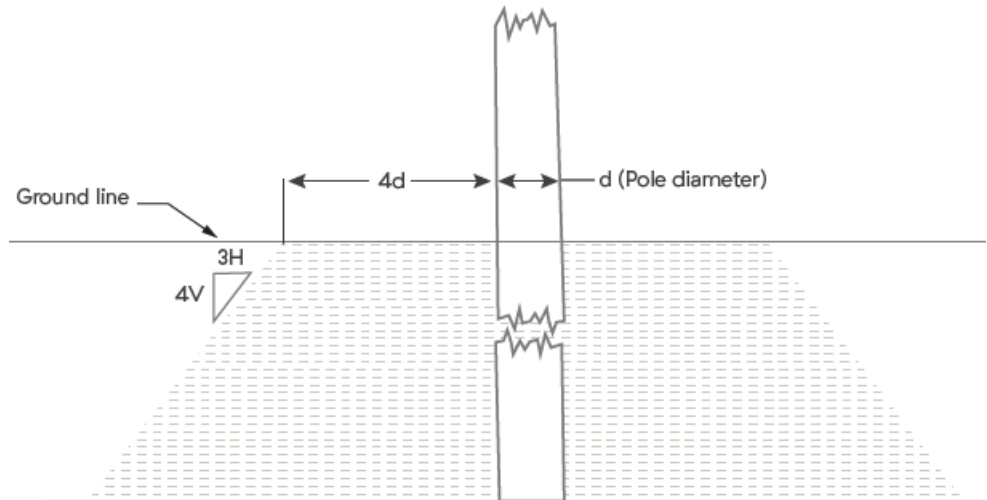

**NOTE:** The **shaded protected zone** encompasses the following area:

- At grade:  $4d$  (4 times the pole diameter) away from the pole
- Below grade (cut angle): **3 m (9'-10")** horizontal to every **4 m (~13')** depth

All excavations and slope cuts must be in accordance with the following AB OH&S Code:

- Part 17 Limits of Approach
- Part 32 Pole Support



## Guy Wires and Anchors

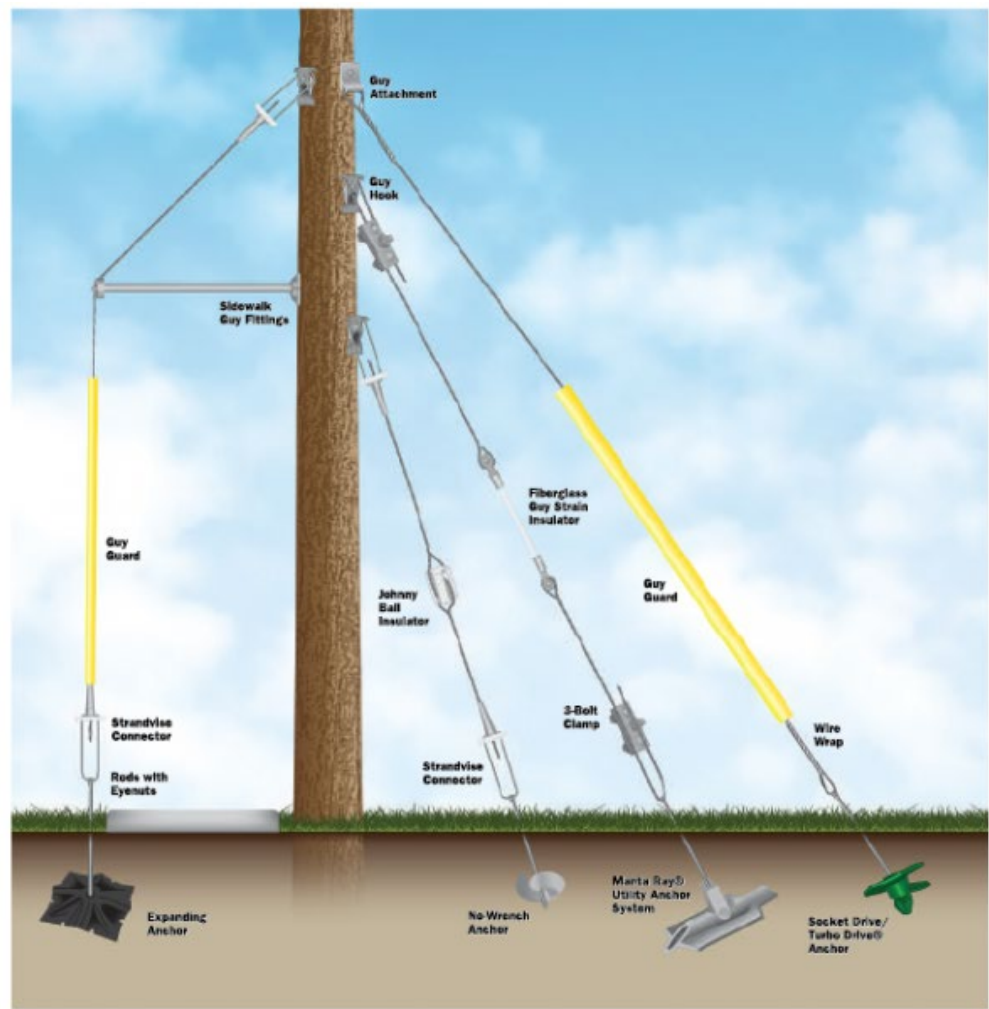

- Guys and/or anchors need to be temporarily removed and replaced (contact [LineInspection@enmax.com](mailto:LineInspection@enmax.com))

### Requirements

Excavators must contact the following:

- ENMAX approved pole tie back vendor for availability and cost
- Damage Prevention Dept. at [LineInspection@enmax.com](mailto:LineInspection@enmax.com) during business hours
- For after hours - Trouble Dispatch at **403-514-6100** if questions/concerns arise

**NOTE: A QUE must complete all pole tie backs.**

### Pole tie back vendors

ENMAX approved pole tie back vendors with an ENMAX approved QUE are listed below.

Tie-back Vendor	Phone Number	Email
Iconic Power Systems	403-899-8318 403-542-4670	<a href="mailto:info@iconicpowersystems.ca">info@iconicpowersystems.ca</a> ; <a href="mailto:jmackay@iconicpowersystems.com">jmackay@iconicpowersystems.com</a>
Primary Engineering	403-333-7099	<a href="mailto:RCoulter@primaryeng.com">RCoulter@primaryeng.com</a>
Valard Construction	403-700-0982 403-710-7099	<a href="mailto:KRyan@Valard.com">KRyan@Valard.com</a> ; <a href="mailto:mchappell@valard.com">mchappell@valard.com</a>

## APPENDIX E - REVISION HISTORY

This document is reviewed a minimum of **every year** or as required.

Rev.	Date	Revision History
1.0	October 11, 2017	New document
2.0	March 30, 2020	Reviewed by stakeholders; updated format
3.0	January 15, 2021	<ul style="list-style-type: none"> <li>Added reference to <a href="#">Primary Switch Disconnect Reconnect Form</a></li> <li>Minor edits</li> </ul>
3.1	June 15, 2021	<ul style="list-style-type: none"> <li>Updated Section 2.5</li> <li>Replaced Senior Line Inspector with Damage Prevention Dept.</li> <li>Added QR Code</li> <li>Updated "Pole tie-back vendors"</li> </ul>
4.0	February 1, 2022	<ul style="list-style-type: none"> <li>Updated references in Appendix B section "Overhead electrical lines"</li> <li>Added a link to AEUC</li> </ul>
5.0	December 22, 2022	<ul style="list-style-type: none"> <li>Stakeholder review November 10<sup>th</sup>, 2022</li> <li>Updated Alberta One-call to Utility Safety Partners</li> <li>Updated the term <a href="#">Conflict zone</a> to include "...of any ENMAX Underground Transmission 69-kV or 138-kV cables"</li> <li>Updated the <a href="#">Primary Switch Disconnect Reconnect Form</a> to <a href="#">Temporary Disconnect/Reconnect Form</a></li> <li>Updated <a href="#">NOTE</a> in Section 2.1.</li> <li>Updated <a href="#">CAUTION</a> in Section 2.1.</li> <li>Added <a href="#">Step i</a> to Section 2.4 to notify <a href="mailto:lineinspection@enmax.com">lineinspection@enmax.com</a></li> <li>Added Step #6 to <a href="#">2.7 PROCEDURE – IF DAMAGE OCCURS</a></li> <li>Added a requirement to <a href="#">safety glasses</a> - minimum IR rating of 1.7</li> <li>Updated <a href="#">WARNING</a> in Appendix B Conflict Zones</li> <li>Removed Altec from the Pole tie back vendors list</li> <li>Added <a href="#">APPENDIX E - ENMAX CONSTRUCTION STANDARDS</a></li> </ul>
5.1	February 2, 2023	<ul style="list-style-type: none"> <li>Updated <a href="#">Section 2.4</a> (shown highlighted for this revision only)</li> <li>Updated Section 2.6 replaced "During business hours" with <a href="#">specific days and hours</a></li> </ul>
5.2	June 15, 2023	<ul style="list-style-type: none"> <li>Removed Liam Preston &amp; added new contact for Iconic Pole tie back</li> </ul>
5.3	Oct 2023	<ul style="list-style-type: none"> <li>Added photos in Appendices B, C and D</li> <li>Added, "to verify line orientation and depth consistency" in minimum Safety precautions.</li> <li>Added, " of 1.2 m and longer" to Section 2.4 Notification for Excavation Activities</li> <li>Appendix B- changed Distribution Facilities to Above Grade facilities</li> <li>Changed Appendix E from Engineered Supports to Engineered Requirements.</li> <li>In 4. DESTRUCTIVE EXCAVATION AND DIRECTIONAL CORING changed to "Maintain <b>1 metre</b> of separation / clearance above, below, and parallel to the cable / facility" as well as changed to "Expose cables to sight at sufficient intervals to maintain separation (typically every 5 m but it may vary based on site specific conditions)" to allow for leeway on expensive driveways</li> </ul>
	Dec 18, 2023	<ul style="list-style-type: none"> <li>Added "unless otherwise specified" to the end of the NOTE in Section 2.2</li> </ul>

		<ul style="list-style-type: none"> <li>• Updated Flowchart for Section 2.8 (moved to beginning of Sect. 2 – Dec 2024)</li> <li>• Highlight in Grey- Section 2.4 ENMAX Projects- Contract in Place</li> <li>• Moved plan revision history to updated Appendix E.</li> <li>• Moved information note: re – contacting 911 for emergencies to front cover.</li> <li>• Updated support requirements for ducts and duct banks with notes.</li> <li>• Updated backfill requirements with notes.</li> <li>• Added Anchor and Guy Wire diagram to Appendix D.</li> <li>• Updated procedure in section 2.7 – step #6</li> </ul>
6.0	August 19, 2024	<ul style="list-style-type: none"> <li>• Updated supplier list for Pole Tie Back Vendors</li> </ul>
7.0	December 4, 2024	<ul style="list-style-type: none"> <li>• Updated flowchart errors- Email address and remove “Buffer Zone”</li> <li>• Removed “Buffer Zone” and utilized either “Conflict Zone” or “Hand Expose Zone”</li> <li>• Update Backfill Section</li> <li>• Inserted Proximity Agreement</li> <li>• Update 2.7 If Damage Occurs <ul style="list-style-type: none"> <li>○ Only ENMAX to Repair</li> <li>○ Cost will be responsibility of Company responsible</li> </ul> </li> <li>• Update 2.8 Conflict Zone verbiage <ul style="list-style-type: none"> <li>○ Remove Buffer Zone with hand Exposure Zone</li> <li>○ Change “No Clearance to Dig” sticker to disclaimer of “No Clearance”</li> </ul> </li> <li>• Update Appendix C – Excavation Methods <ul style="list-style-type: none"> <li>○ Add “At no point, exposed or not, can you use mechanical tools on ducts with energized cable...No chipping of ducts/duct banks.”</li> </ul> </li> </ul>
8.0	December 12, 2024	<ul style="list-style-type: none"> <li>• Moved Disturbance Guideline chart to beginning of section 2.</li> <li>• Updated exposure guidelines for shallow duct banks.</li> </ul>